

Instructions

Melt Pressure Sensor

PT-NK-0, PT-NK-1, PT-NK-2



attestation

ISO 9001, 14001, 45001, 10002 & 31000

Please read this instruction manual carefully before installation



Content

1. Introduction
2. Application
3. Product features
4. Technical data
5. Dimensions
6. Electrical connection and debugging
7. Ordering Guide
8. Installation and Removal
9. Sensors cleaning
10. Transport and storage

Introduction

PT-NK-X series adopts patented environmental friendly alloy filling and upgraded version of AFT vacuum filling technology, which are safe and non-toxic, high temperature resistance, and stable performance.

Application

PT-NK-X series are suitable for the control of the extrusion process of clean materials such as sheets, composite materials, films, pipes, food packaging, medical packaging, etc.

Product Features

- AFT technology environment-friendly alloy medium filling
- The highest temperature resistance can reach 400°C
- Several diaphragm materials are optional
- With SIL2 & RoHS certificate
- One-key rezero is easy to debug on site

Technical Data

Pressure Range	0~35bar ; 0~2000bar	0~100bar ; 0~2000bar
Accuracy	±0.5% ; ±0.25%	
Over load Pressure	1.5FSO	
Bridge Resistance	350 Ω Wheatstone bridge	
Output Signal	4-20mA	0~10Vdc ,0~5Vdc 3.33mV/V
Power	9~36Vdc(Standard24Vdc)	18~36Vdc 6~12Vdc(Standard10Vdc)
Load Resistance Ω	<(U-9)/0.02	>10k ---
Calibration	80%FSO	
Process Connection	M14×1.5 , 1/2UNF , M18×1.5	
Insulation Resistance (50Vdc)	1000MΩ	
Diaphragm Material	17-4PH , inconel718 , C276	
Diaphragm Max Temp	400°C	
Film Material	TiAlN	
E-connection	6-pin connector(Standard) , 8-pin connector(Standard)	
Electrical Environment Temp	-20°C~85°C	
Thermocouple	J Type , E Type , K Type , pt100	
Protection Degree	IP65	
Installation Torque	<30Nm	
Filing Material	ATF Alloy-filling	

Dimensions

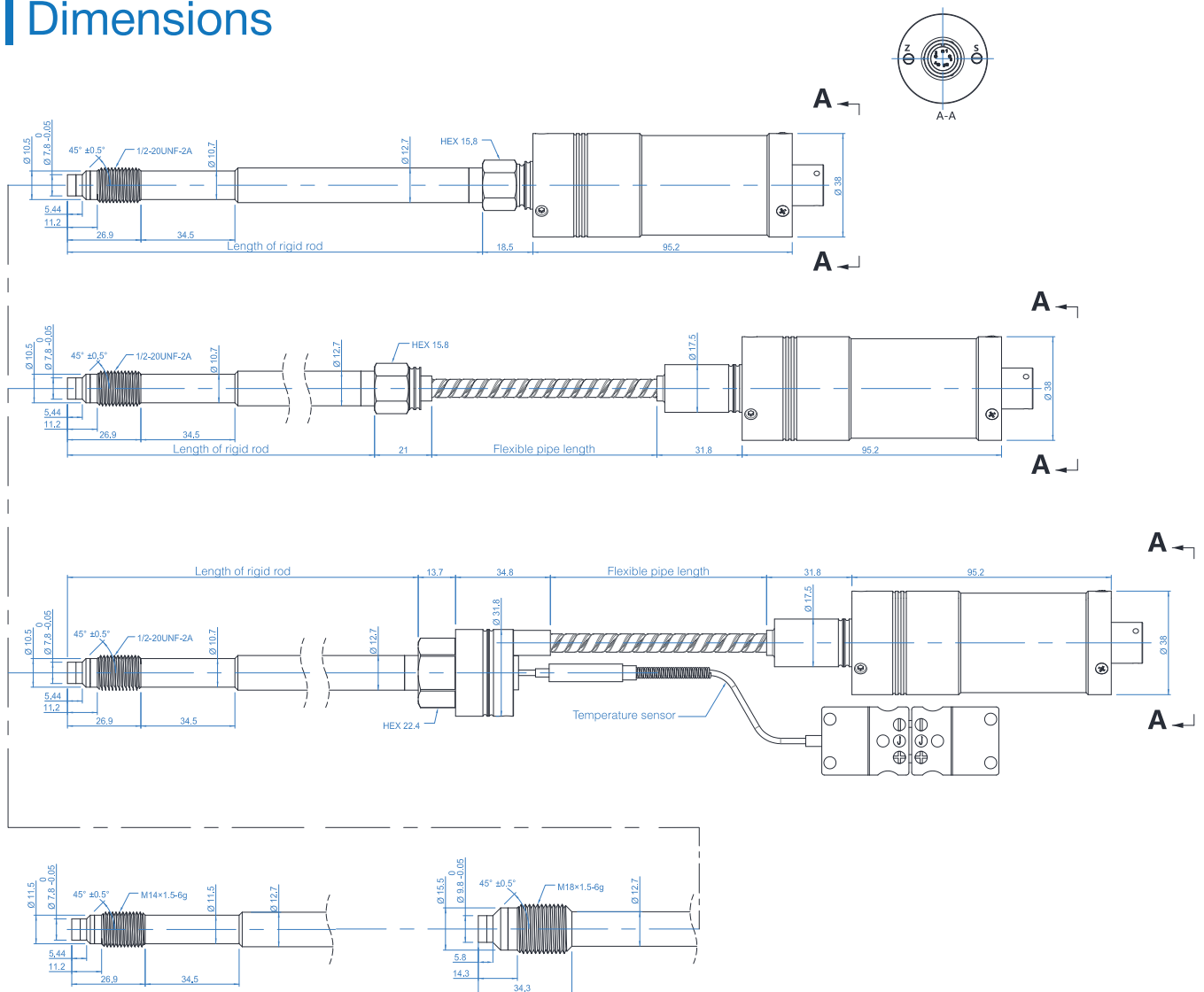

Electrical connection & Debugging

After the pressure sensor has been installed on the line, the electrical connections must be made as shown in the wiring diagram below.

The PT-NK-X series is equipped with an integrated amplification circuit, the calibration process must be the pipeline is heated and the pressure is zero. The zero point is adjusted by activated autozero function, which is via shorting two pins together (see wiring) or adjusted by twisting the "Z" position screw at the top of the shell with an object like toothpick, press button 3 seconds to reset zero (please do not touch "S" point). mV signal without this function, can reset zero through the back - end instrument. The output signal is then detected by 80% (see the wiring diagram), and it will provide a signal of a standard 80% measurement.

3.33mV/V (4-wire)

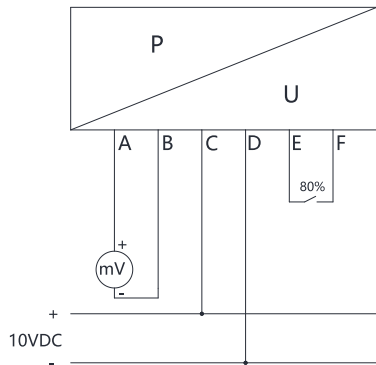

6-pin connector /PT02A-10-6P

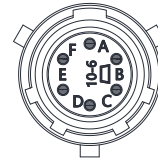

PIN	Function	Wire Color
A	Signal+	Red
B	Signal-	Black
C	Power+	White
D	Power-	Green
E	80%+	Blue
F	80%-	Orange

4□20mA (2-wire) (Auto zero)

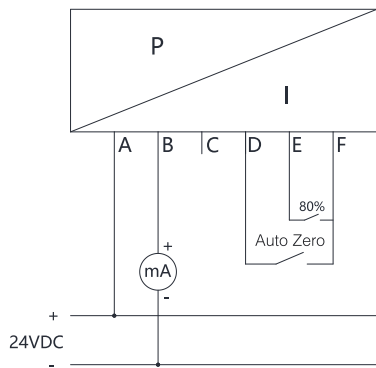

6-pin connector /PT02A-10-6P

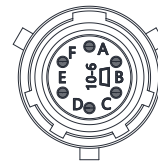

PIN	Function	Wire Color
A	Power+	Red
B	Power-	Black
C		White
D	Shorting D&F to rezero+	Green
E	80%+	Blue
F	Shorting D&F to rezero+/80%-	Orange

4□20mA (2-wire) (One key to reset zero)

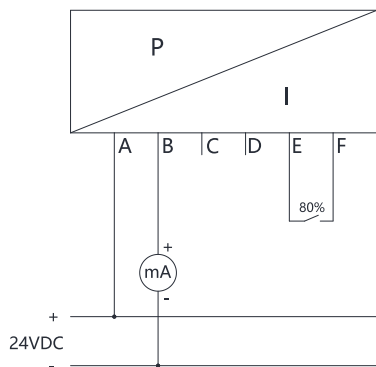

6-pin connector /PT02A-10-6P

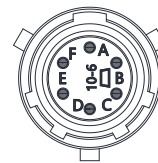

PIN	Function	Wire Color
A	Signal+	Red
B	Signal-	Black
C	Power+	White
D	Power-	Green
E	80%+	Blue
F	80%-	Orange

0□5V/10V (4-wire) (Auto zero)

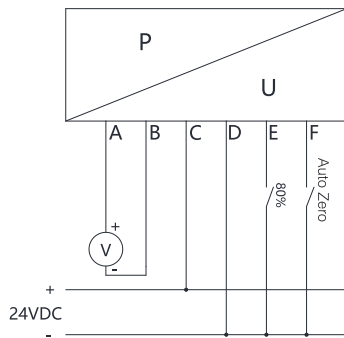

6-pin connector /PT02A-10-6P

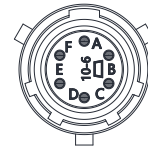

PIN	Function	Wire Color
A	Signal+	Red
B	Signal-	Black
C	Power+	White
D	Power- / 80%- / Shorting D&F to rezero-	Green
E	80%+	Blue
F	Shorting D&F to rezero+	Orange

*B and D pins are connected internally

0□5V/10V (4-wire) (One key to reset zero)

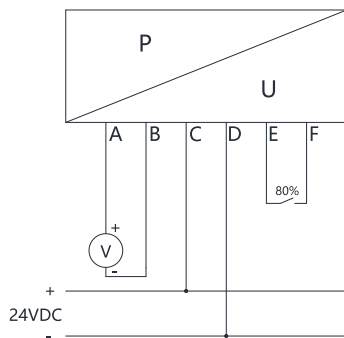

6-pin connector /PT02A-10-6P

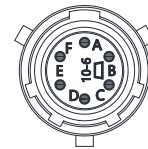

PIN	Function	Wire Color
A	Signal+	Red
B	Signal-	Black
C	Power+	White
D	Power-	Green
E	80%+	Blue
F	80%-	Orange

*B and D pins are connected internally

The cable shall be covered with shielding layer cable, each core wire is about 0.3 mm² temperature-resistance is not less than 105°C, each core wire connection column shall be insulated and protected by heat shrink tube isolation, shield wire shall be connected with plug-in metal, cable welding should be particularly careful otherwise it may lead to signal transmission error or damage products, it is recommended to use MPS welded special cable. For excess lines in the cable, each wire should be wrapped separately with insulating tape.

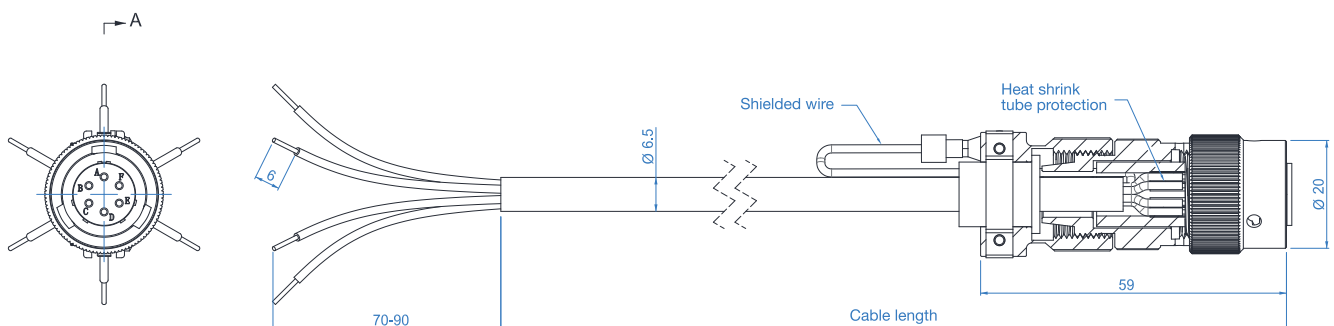

VIEW A-A

Installation & Removal

When installing the pressure sensor, the sensor hole should be within the size requirement marked in following drawing and the assembly accuracy can be checked by testing bolts. Before installing the sensor, first clean the impurities in the hole and between the threads, then the thread of the sensor is coated with heat-resistant slurry, the screw teeth can be avoided. The installation force is very important, the installation torque of the sensor can only act on the shaft (hexagon), do not apply any force to the head of the sensor. The housing should be kept away from high temperature areas.

1/2-20 UNF /M14×1.5= Maximum starting torque: 40Nm

M18 x 1.5 = Maximum starting torque: 50 Nm

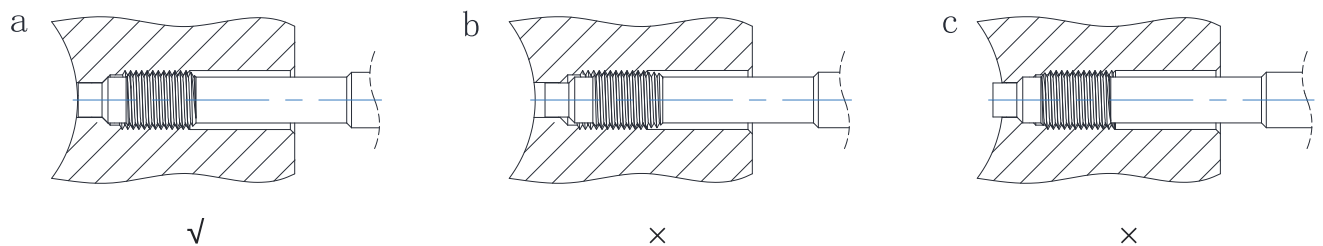

Removal

The removal of the pressure sensor (transmitter) must be done under heating conditions (plastic melting point). When removing the sensor (transmitter), note that the diaphragm has no contact pressure. The force to unload the sensor (transmitter) must be applied on the shaft (hexagon), and do not apply any force to the head of the sensor (transmitter).

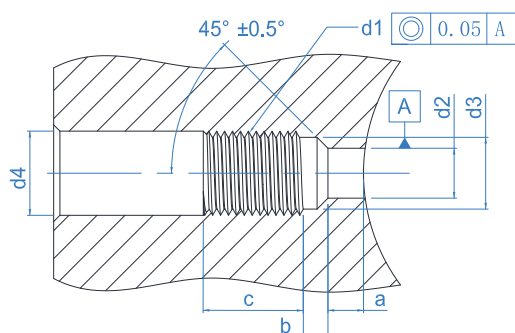

d1	M18×1.5	M14×1.5	1/2-20UNF-2A
d2	∅ 9.9 ^{+0.1}	∅ 7.9 ^{+0.1}	∅ 7.9 ^{+0.1}
d3	∅ 16.1 ^{+0.1}	∅ 11.7 ^{+0.1}	∅ 10.7 ^{+0.1}
d4	∅ 20	∅ 15	∅ 14
a	6.1 ^{-0.1}	5.7 ^{-0.1}	5.7 ^{-0.1}
b	4 ^{-0.2}	3.2 ^{-0.2}	3.2 ^{-0.2}
c	25	19	19

| Sensors cleaning

In order to clean the diaphragm, the sealing surface and thread of the transmitter must have the same temperature as the melting point of the plastic. The diaphragm and sealing surface can be cleaned with soft cloth, and rigid rod can be cleaned with steel brush or copper brush. (Do not touch diaphragm surface with the steel brush.)

| Transport and storage

PT-NK-X Series melt pressure sensors (transmitters) are usually packaged separately. At the front thread of the rigid rod, the induction diaphragm is protected by a protective cap. This protective cap should be tightened at any time during storage, and only opened during installation.

Note: Mounting brackets, extension cables, connectors, cleaning kits, drill kits, dummy plug etc accessories, please contact with us.