

Instructions

Melt Pressure Sensor

PT-EPF-A-0 / PT-EPF-A-1 / PT-EPF-A-2 Series (4- 20 m A + H art)



attestation

ISO 9001, 14001, 45001, 10002 & 31000

Please read this instruction manual carefully before installation



Content

1. Introduction
2. Application
3. Product features
4. Technical data
5. Dimensions
6. Electrical connection and debugging
7. Ordering Guide
8. Installation and Removal
9. Sensors cleaning
10. Transport and storage

Introduction

PT-EPF-A-X series is an intelligent 4...20 mA Hart protocol melt pressure sensor design for explosive hazardous sites. It uses all stainless steel welding structure, thread and flange installation mode are optional. High performance core components can help it get high measurement accuracy.

Application

It is widely used in melt pressure process measurement control of high precision polymer extrusion equipment, production line and laboratory equipment and laboratory instruments.

Product Features

- Several flange connections are available
- 4-20mA, 4-20mA+Hart output
- Fully welded housing optional
- CE, Ex and other electrical safety and explosion-proof tests

Technical Data

Pressure Range	0~35bar ; 0~2000bar
Accuracy	±0.5% ; ±0.25%
Over load Pressure	1.5FSO
Bridge Resistance	350Ω Wheatstone bridge
Power	12~30Vdc(Standard24Vdc)
Output Signal	4-20mA , 4~20mA+hart
Load Resistance ▲	<(U-12)/0.02
Explosion-proof grade	Exiall CT4 , Exiall CT6
Process Connection	1/2-20UNF , Flange connection
Insulation Resistance (50Vdc)	1000MΩ
Diaphragm Material	17-4PH , inconel718 , C276
Diaphragm Max Temp	400 °C
Film Material	TiAIN
E-connection	1/2NPT leading wire , 6-pin connector(Standard)
Electrical Environment Temp	-20°C ~ 85°C
Thermocouple	J Type , E Type , K Type , pt100
Protection Degree	IP65
Installation Torque	<30Nm
Filing Material	Mercury filing

Dimensions

Thread

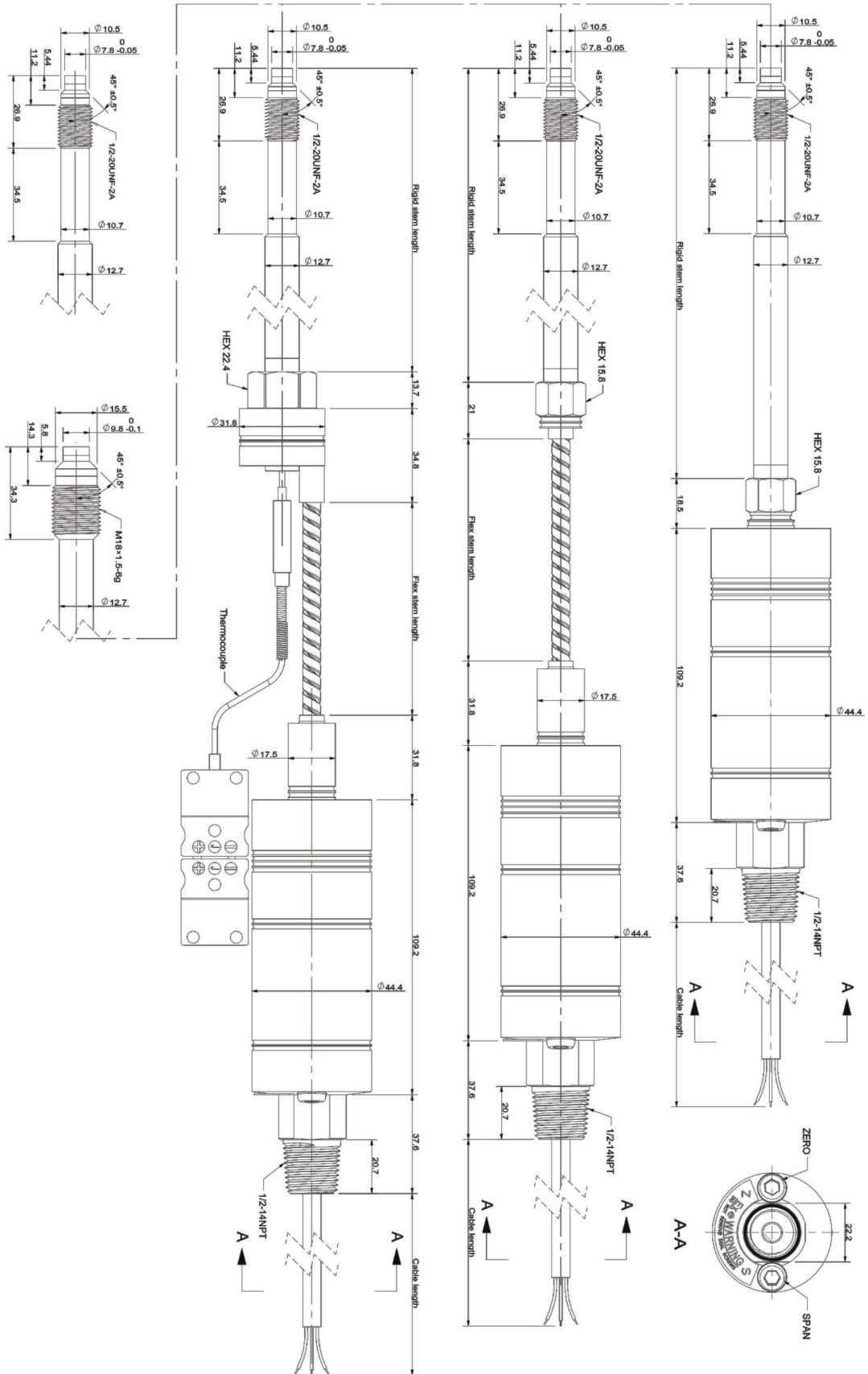

ø66.8 Flange

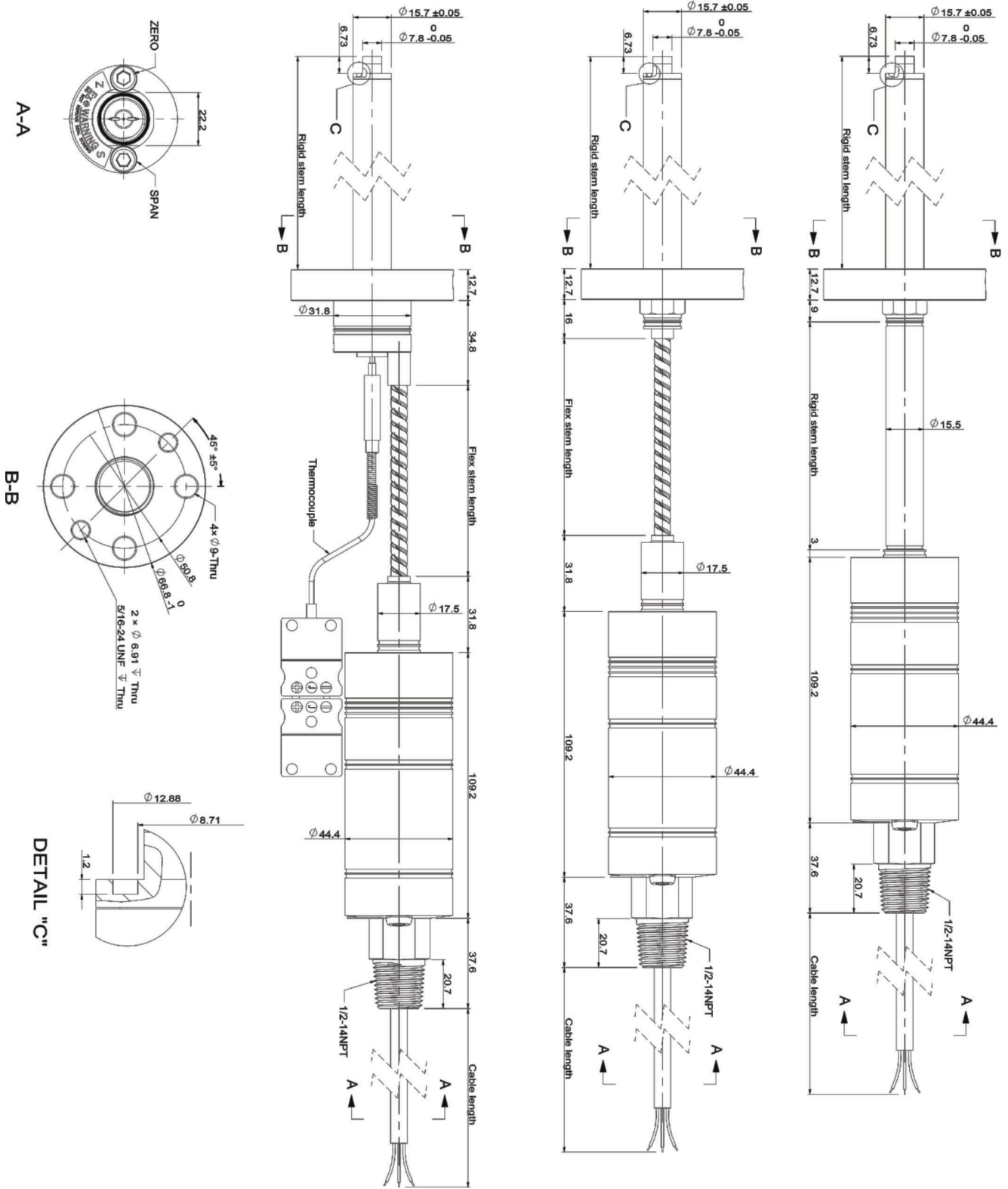

ø82.6 Flange

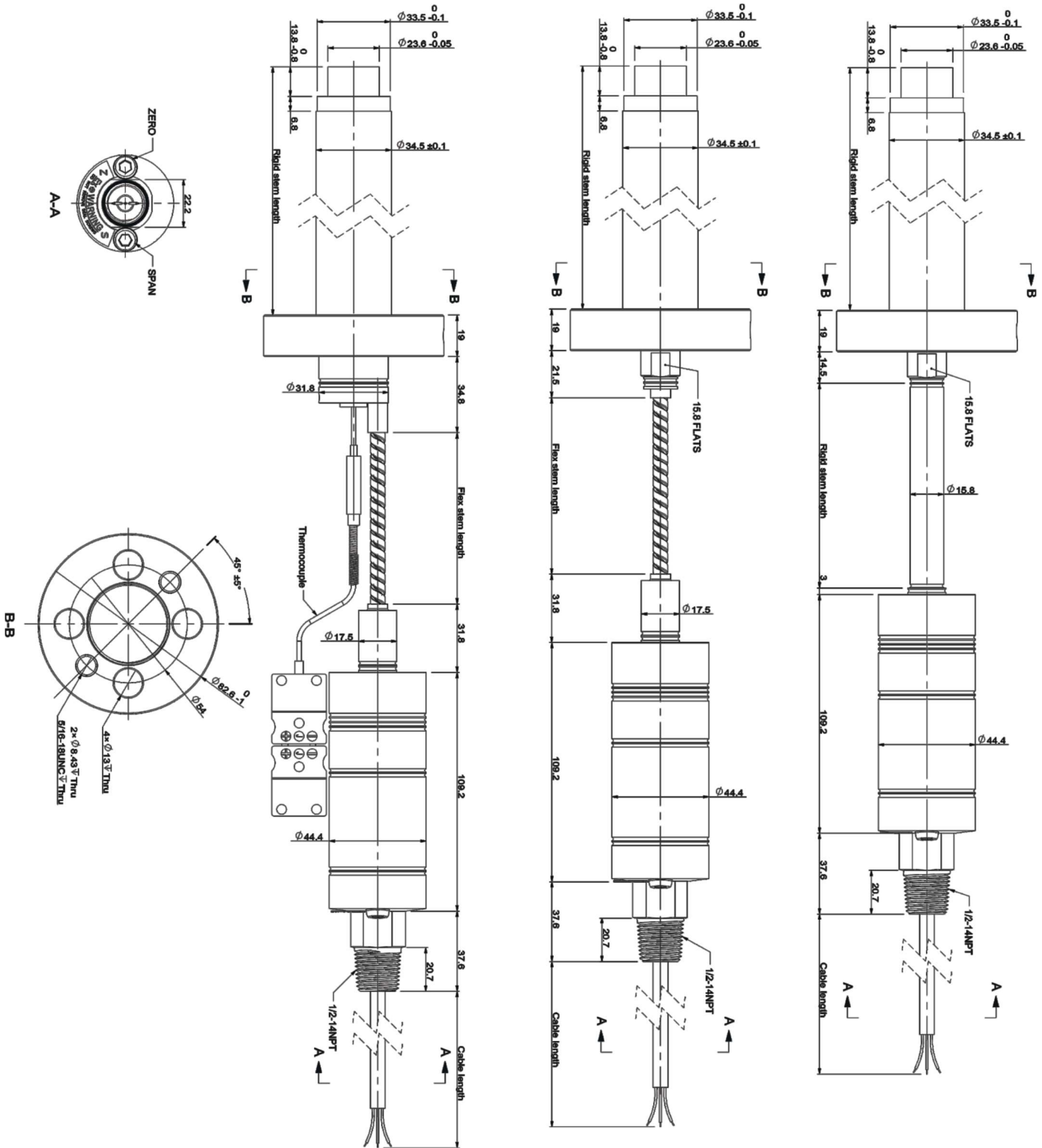

Sealing Washer

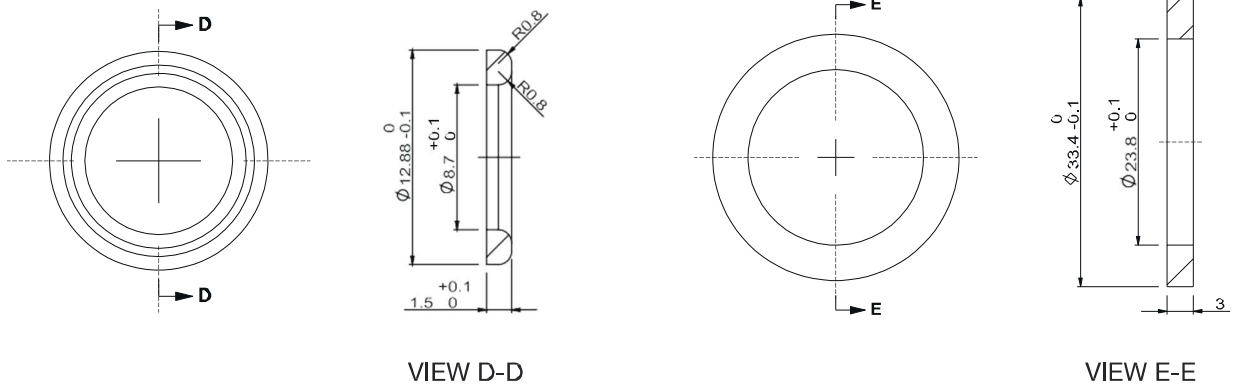

ø66.8 Flange sealing gasket

ø82.6 Flange sealing gasket

Electrical connection & Debugging

After the pressure transmitter has been installed on the pipeline, the electrical connection must be in accordance with the connection shown in the wiring diagram below.

This series is equipped with an integrated amplifier circuit. The rezero process must be operated when the pipeline is heated and the pressure is zero. The zero point is adjusted by twisting the top of the shell "Z" position screw, use a object like a toothpick, lightly press the button inside for 5s, then release it, and quickly press the button again to reset zero (Do not touch S" position). Hart converter can also be used to connect the Hart converter in series on the power line a 250Ω resistance, the two ends of the converter are respectively connected to the two ends of the resistance (see the wiring diagram below).

4...20mA+Hart (2-wire)

6-pin connector / PT02A-10-6P

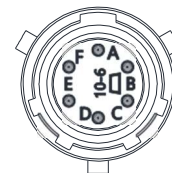
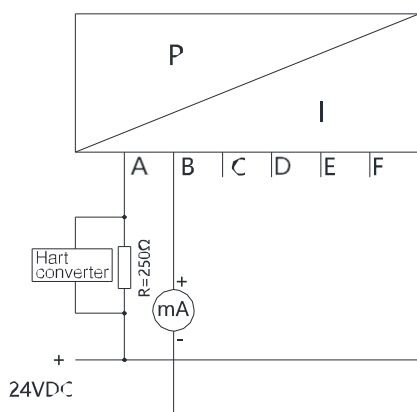

PIN	Function	Wire Color
A	Power+	Red
B	Power-	Black
C		White
D		Green
E		Blue
F		Orange

4...20mA+Hart (2-wire)

1/2NPT lead wire □X□meters

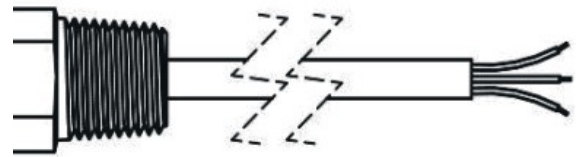
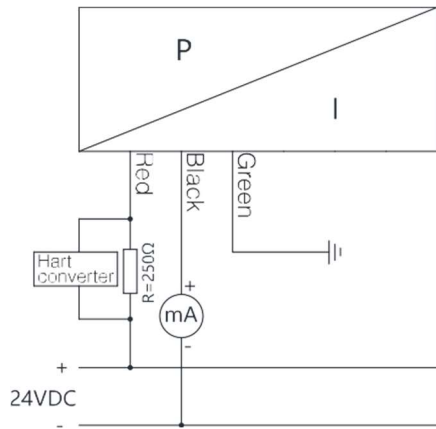

Function	Wire Color
Power+	Red
Power-	Black
Ground	Green

The cable shall be covered with shielding layer cable, each core wire is about 0.3 mm², temperature-resistance is not less than 105°C, each core wire connection column shall be insulated and protected by heat shrink tube isolation, shield wire shall be connected with plug-in metal, cable welding should be particularly careful, otherwise it may lead to signal transmission error or damage products. It is recommended to use MPS welded special cable.

For excess lines in the cable, each wire should be wrapped separately with insulating tape.

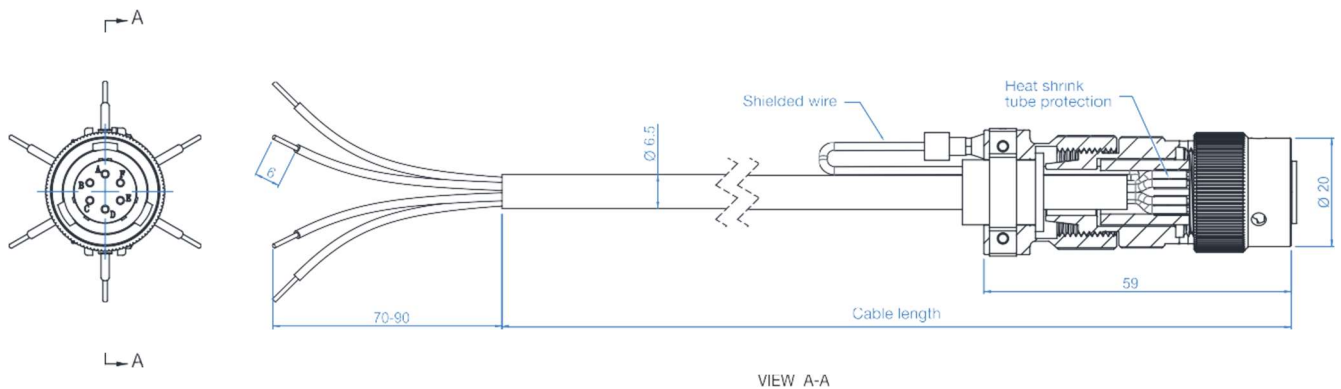

Installation & Removal

Installation

Thread Installation ,when installing the pressure sensor, the sensor hole should be within the size requirement marked in following drawing and the assembly accuracy can be checked by testing bolts. Before installing the sensor, first clean the impurities in the hole and between the threads, then the thread of the sensor is coated with heat-resistant slurry, the screw teeth can be avoided. The installation force is very important, the installation torque of the sensor can only act on the shaft (hexagon), do not apply any force to the head of the sensor. The housing should be kept away from high temperature areas.

Flange installation, according to the characteristics of the medium, should be added to the sealing surface suitable sealing gasket, processing size see Chapter 9 drawing sealing gasket.

1/2-20 UNF /M14×1.5= Maximum starting torque: 40Nm

M18 x 1.5 = Maximum starting torque: 50 Nm

Flange installation=Maximum starting torque: 50 Nm

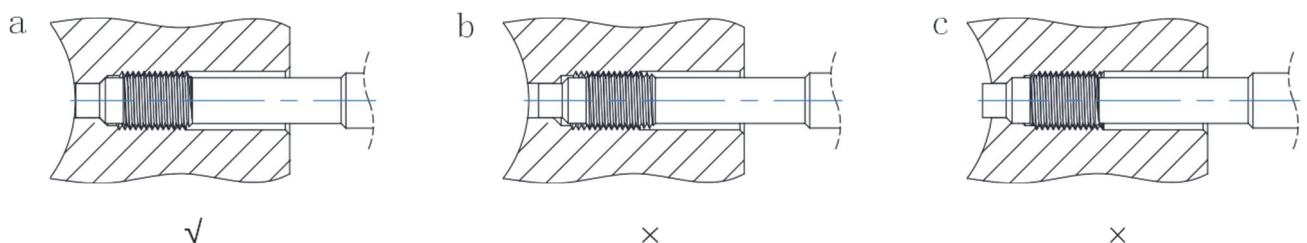

Removal

The removal of sensor must be done under heated conditions (plastic melting point). When remove the sensor, please note that the diaphragm has no contact pressure. The force to remove the sensor must only be applied on the shaft (hexagon), and do not apply any force to the head of the sensor.

Thread Installation

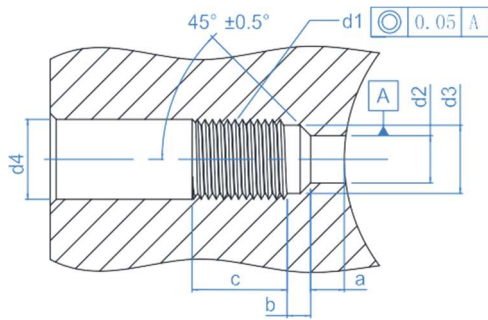

d1	M18×1.5	M14×1.5	1/2-20UNF-2A
d2	∅ 9.9 ^{+0.1}	∅ 7.9 ^{+0.1}	∅ 7.9 ^{+0.1}
d3	∅ 16.1 ^{+0.1}	∅ 11.7 ^{+0.1}	∅ 10.7 ^{+0.1}
d4	∅ 20	∅ 15	∅ 14
a	6.1 ^{-0.1}	5.7 ^{-0.1}	5.7 ^{-0.1}
b	4 ^{-0.2}	3.2 ^{-0.2}	3.2 ^{-0.2}
c	25	19	19

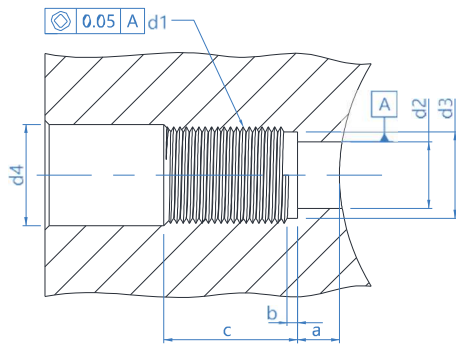

D1	∅ 66.8	∅ 82.6
D2	∅ 50.8	∅ 54
D3	M8	M12
D4	∅ 6.8	∅ 10.4
D5	∅ 7.9 ^{+0.1}	∅ 23.8 ^{+0.1}
D6	∅ 16.5 ^{+0.1}	∅ 35.5 ^{+0.1}
A	6.8 ^{+0.1}	14 ^{+0.1}
B	13.9 ^{+0.1}	124 ^{+0.1}

Sensors cleaning

In order to clean the diaphragm, the sealing surface and thread of the sensor must have the same temperature as the melting point of the plastic. Both the diaphragm and the sealing surface can be wiped clean with a soft cloth, and the thread can be cleaned with a steel brush or a copper brush.

(Do not touch the surface of the diaphragm with the steel brush.)

Transport and storage

PT-EPF-A-X pressure transmitter is usually packaged individually, the front threads of the rigid rod and the diaphragm is protected by a protective cap. This protective cap should be tightened at any time during storage, and only opened during installation.

Note: Mounting brackets, extension cables, connectors, cleaning kits, drill kits, dummy plug etc accessories, please contact with us.